

⊗ 2W-5W Filament type bulb



# WOSP Dynator instructions

Alternators / Dynators are polarity sensitive therefore always ensure you have correct unit for the vehicle to prevent damage being caused.

## 12V Negative & Positive Earth / Ground

A dynator is an alternator disguised as a generator. These units are perfect for those looking for a more modern, powerful & reliable unit whilst retaining a classic / original look. Made to fit identically in place of the original dynamo / generator, the WOSP dynator no longer requires an external regulator control box as they're all internally regulated. We offer a small range of dummy regulator control boxes to replace the three most common Lucas types predominantly fitted to British vehicles to be used in conjunction with the dynator, or you can bypass your existing bulkhead mounted regulator / use it as a junction point.

### Wiring Instructions (If retaining original regulator & not bypassing or fitting a dummy regulator control box)

1. Transfer your pulley across to the Dynator if you're not using the pulley supplied with it or have ordered the correct pulley separately.
2. Disconnect your battery.
3. Replace your original dynamo with your WOSP dynator.
4. Disconnect the earth from your regulator control box.
5. Move the small wire coming from your warning light to 'D' on the regulator control box and join it to the small wire which currently comes from the old dynamo and connects to the 'F' post on the regulator control box.
6. Move the larger wire coming from your dynamo to 'D' on the regulator control box and add this to your 'A' or 'B' of you respective regulator.
7. Ensure all wires are connected properly and reconnect your battery.

### RB106 (Screw & Spade types)

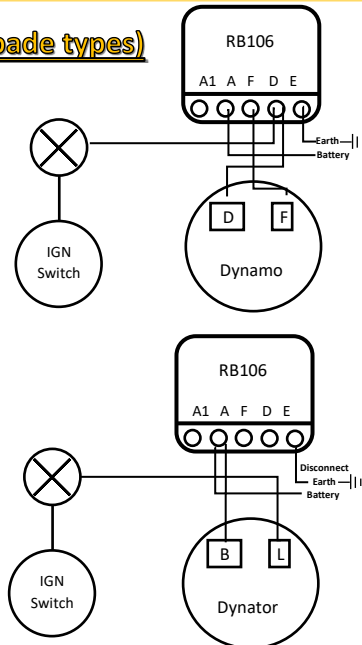

### RB340

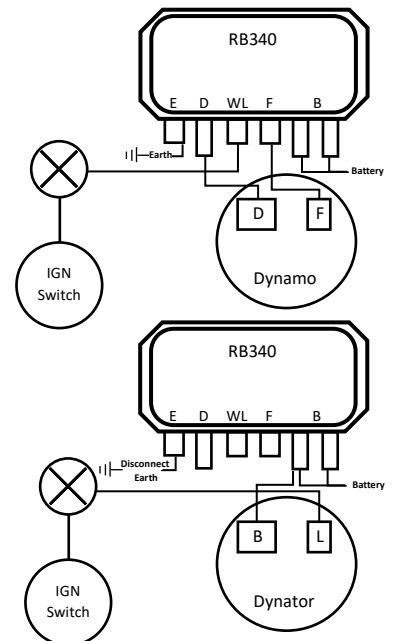

### RF95

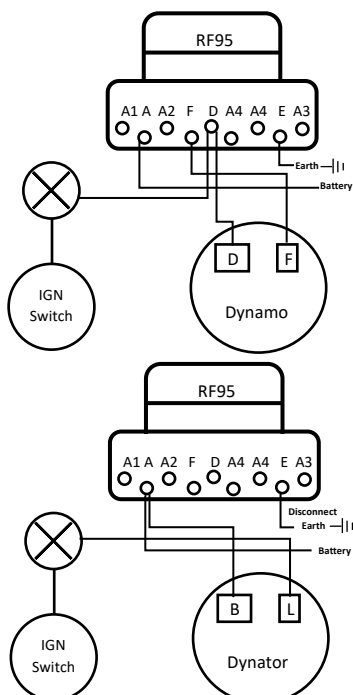

### RB130

